

PORCESSHINE

PORCELÁNICO PULIDO / POLISHED PORCELAIN

Dakar

Fantasy *NEW*

Garbi *NEW*

Milos

Noir *NEW*

Patagonia *NEW*

Radón

Vanity

PERFECCIÓN EN ALTO BRILLO
*PERFECTION IN HIGH GLOSS
BRILLANCE ULTIME PARFAITE*



Dakar — Porcesshine



Dakar White 60x120

Dakar



Dakar White



Dakar Grigio



Dakar Brown



Dakar Blue







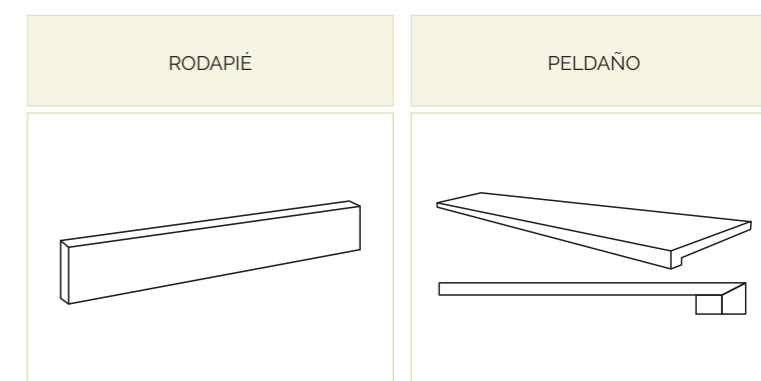

Dakar Brown 60x120

Piezas complementarias
Complementary Tiles / Pièces Complémentaires



Formatos / Formats



	Formato	Pz/cj	Pz/pl	M ² /cj	M ² /pl	Cj/pl	Kg/cj	Kg/Total
	60x120  	2	64	1,44	46,08	32	34,50	1129
	120x120  	1	36	1,44	51,84	36	38,40	1422,4
	Porcesshine	60x120 / 120x120 23.62"x47.24" / 47.24"x47.24"						



Fantasy NEW — Porcesshine



Fantasy NEW

Fantasy Pink 60x120



Fantasy Pink



Fantasy Acqua



Fantasy Topo



Fantasy Green



Fantasy Green 120x120

Piezas complementarias
Complementary Tiles / Pièces Complémentaires

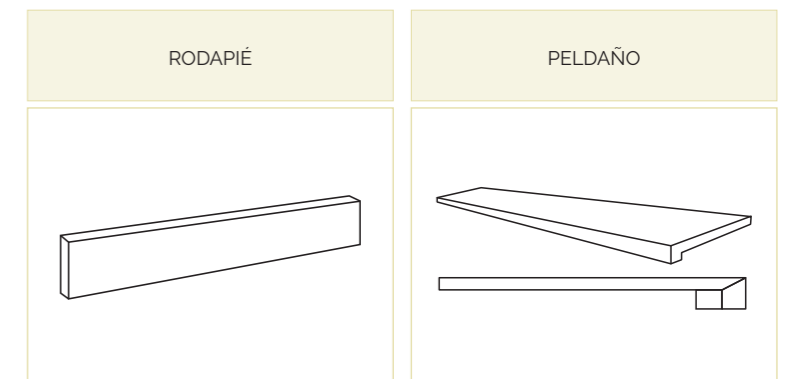

Formatos / Formats



60x120



120x120

	Formato	Pz/cj	Pz/pl	M ² /cj	M ² /pl	Cj/pl	Kg/cj	Kg/Total
	60x120	2	64	1,44	46,08	32	34,50	1129
	120x120	1	36	1,44	51,84	36	38,40	1422,4
	Porcesshine	60x120 / 120x120 23.62"x47.24" / 47.24"x47.24"						



Garbi NEW — Porcesshine



Garbi Navi 60x120

Garbi



Garbi Metal



Garbi Navi



Garbi Oxid

Piezas complementarias
Complementary Tiles / Pièces Complémentaires

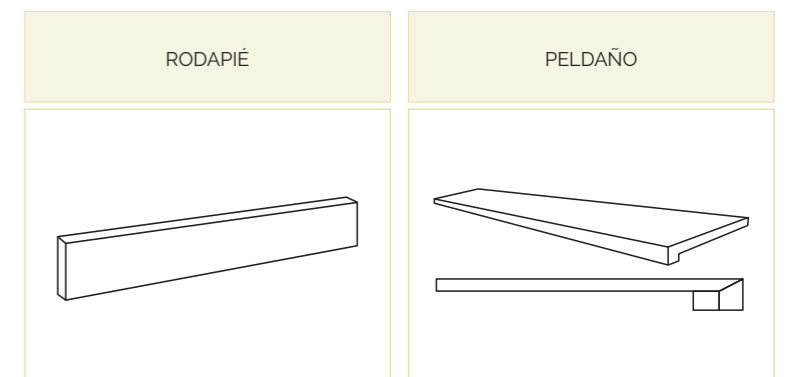

Formatos / Formats



60x120
☞ ☠



120x120
☞ ☠

	Formato	Pz/cj	Pz/pl	M ² /cj	M ² /pl	Cj/pl	Kg/cj	Kg/Total
☞ ☠ ☠ ☠ ☠	60x120 ☞ ☠	2	64	1,44	46,08	32	34,50	1129
	120x120 ☞ ☠	1	36	1,44	51,84	36	38,40	1422,4
	Porcesshine	60x120 / 120x120 23.62"x47.24" / 47.24"x47.24"						



Milos — Porcesshine



Milos Brown 120x120

Milos



Milos Black



Milos Blue

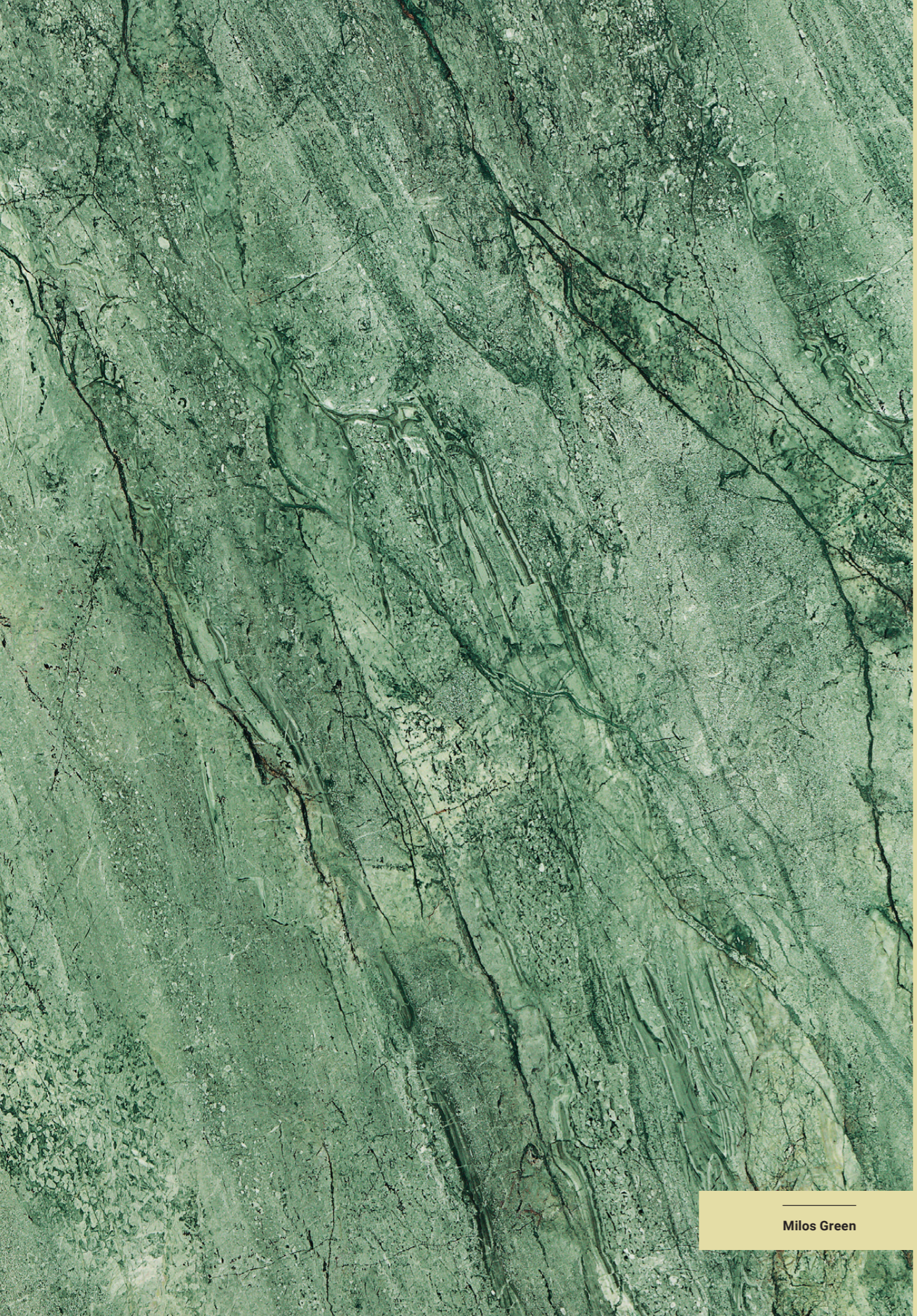

Milos Green



Milos Brown



Milos Brown 120x120

Piezas complementarias
Complementary Tiles / Pièces Complémentaires

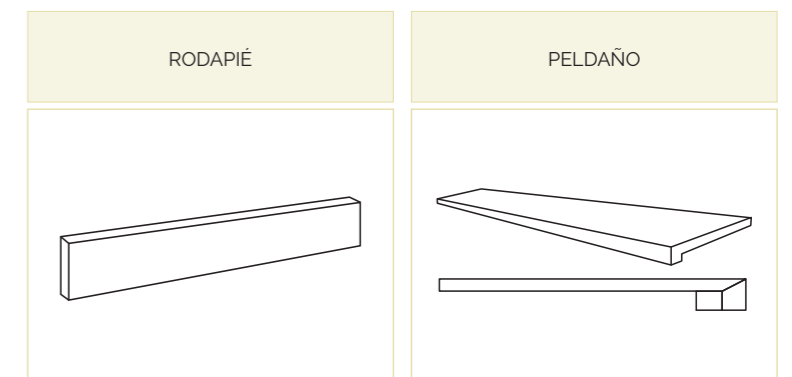

Formatos / Formats

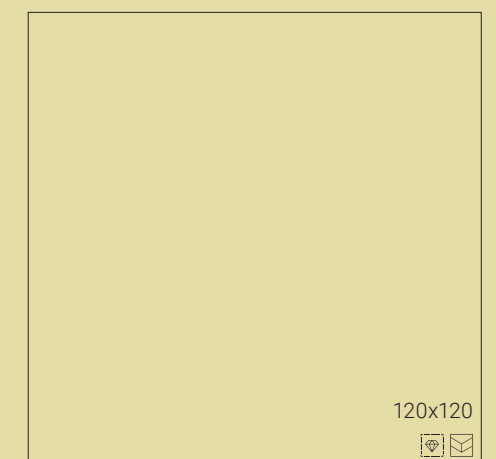

	Formato	Pz/cj	Pz/pl	M ² /cj	M ² /pl	Cj/pl	Kg/cj	Kg/Total
	60x120	2	64	1,44	46,08	32	34,50	1129
	120x120	1	36	1,44	51,84	36	38,40	1422,4
Porcesshine		60x120 / 120x120 23.62"x47.24" / 47.24"x47.24"						



Noir NEW — Porcesshine



Noir Black 120x120

Noir



Noir Black

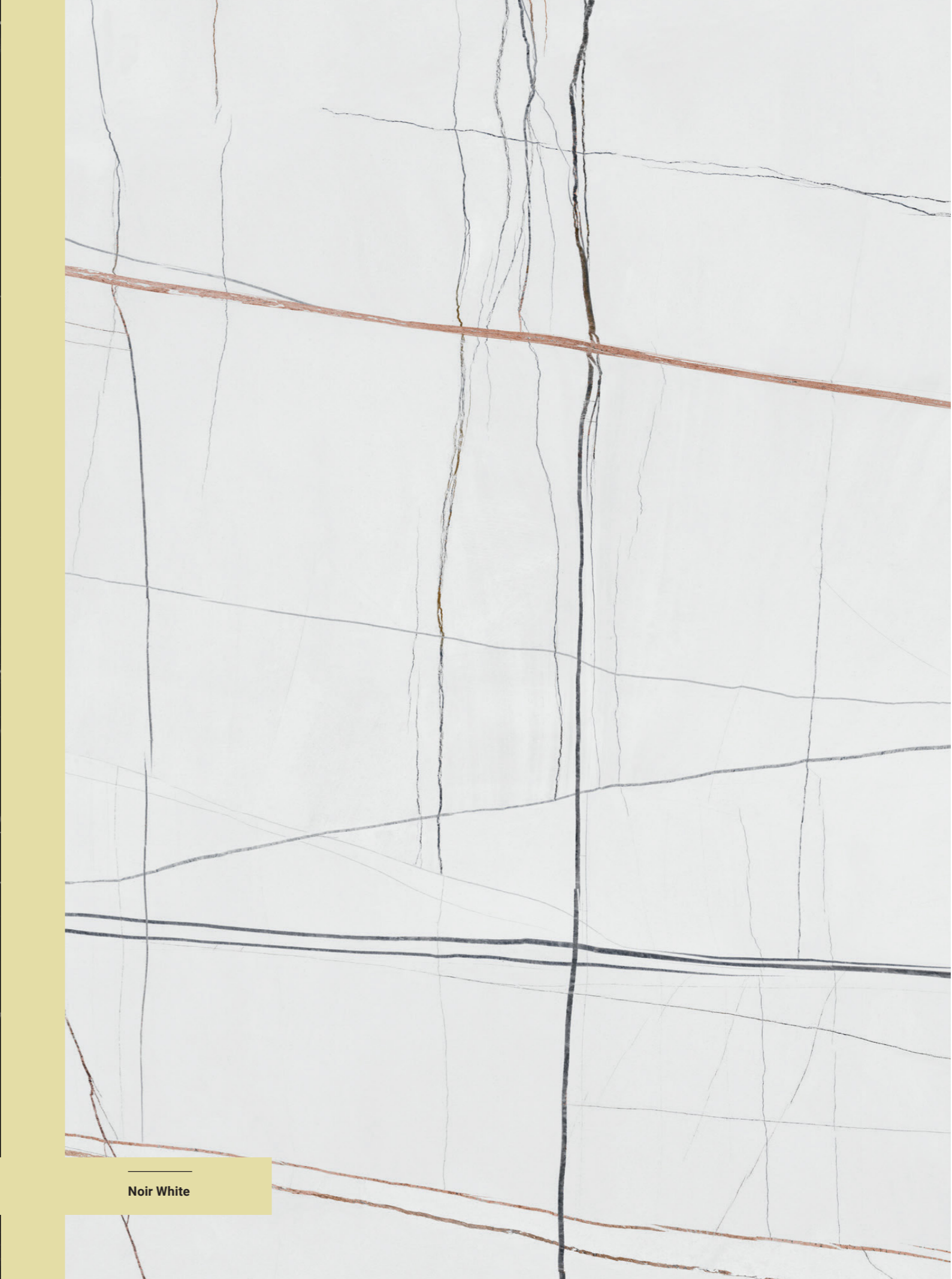

Noir White



Noir White 120x120

Piezas complementarias
Complementary Tiles / Pièces Complémentaires

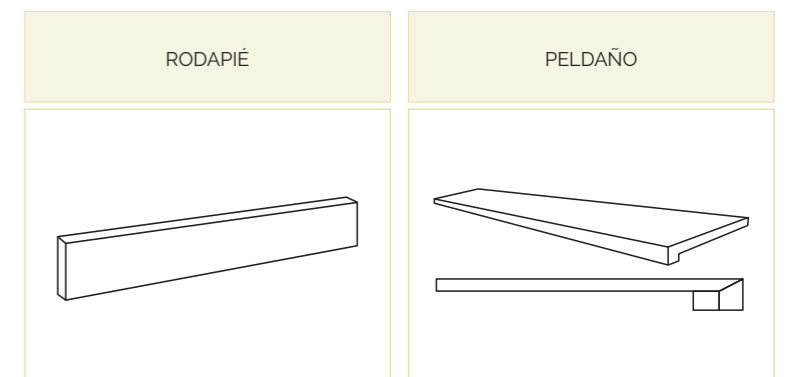

Formatos / Formats





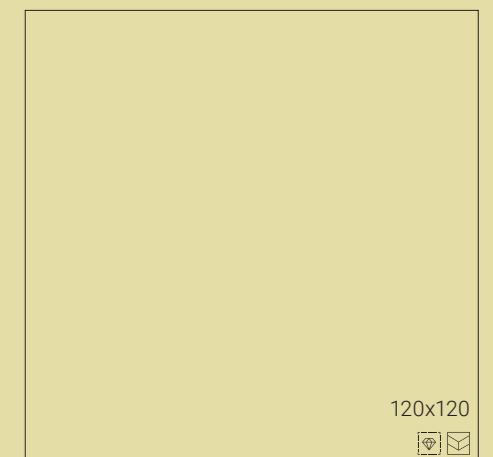

60x120



120x120



Formato	Pz/cj	Pz/pl	M²/cj	M²/pl	Cj/pl	Kg/cj	Kg/Total
60x120  	2	64	1,44	46,08	32	34,50	1129
120x120  	1	36	1,44	51,84	36	38,40	1422,4
Porcesshine	60x120 / 120x120 23.62"x47.24" / 47.24"x47.24"						



Patagonia NEW — Porcesshine



Patagonia Blue 60x120

Patagonia



Patagonia Blue

Piezas complementarias
Complementary Tiles / Pièces Complémentaires

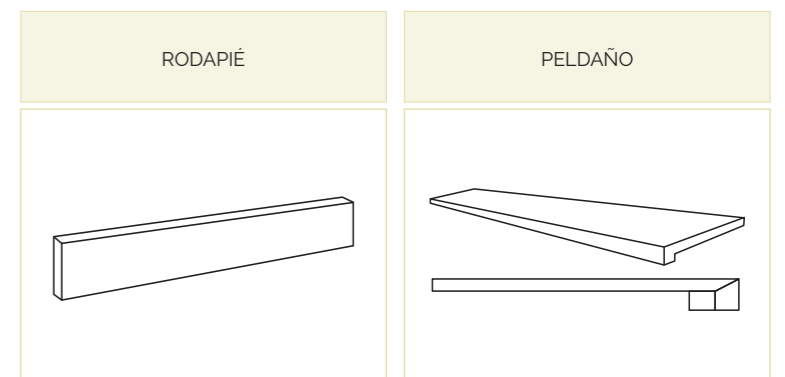

Formatos / Formats

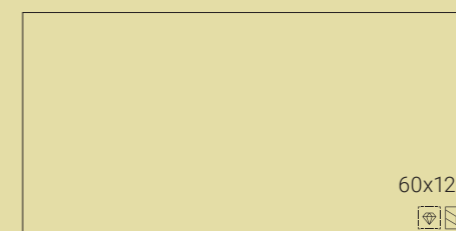

60x120
☑️☑️

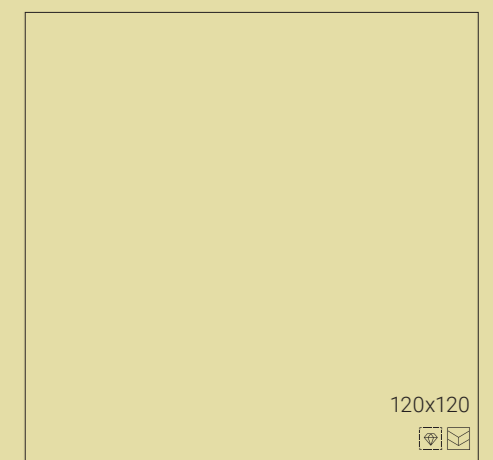

120x120
☑️☑️



Formato	Pz/cj	Pz/pl	M ² /cj	M ² /pl	Cj/pl	Kg/cj	Kg/Total
60x120 ☑️☑️	2	64	1,44	46,08	32	34,50	1129
120x120 ☑️☑️	1	36	1,44	51,84	36	38,40	1422,4

Porcesshine 60x120 / 120x120
23.62"x47.24" / 47.24"x47.24"



Radón — Porcesshine



Radón Negro 120x120

Radón



Radón Negro

Piezas complementarias
Complementary Tiles / Pièces Complémentaires

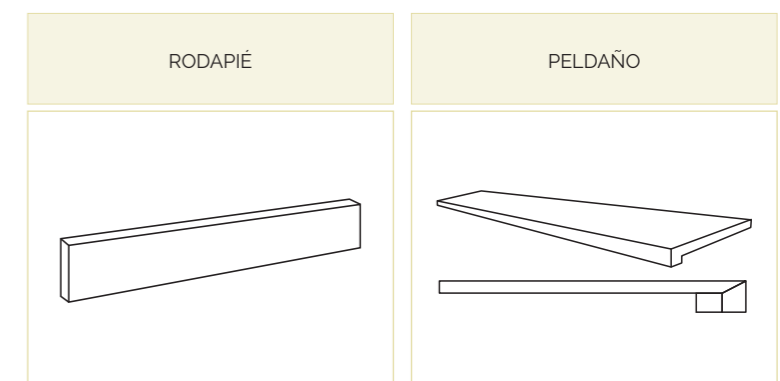

Formatos / Formats

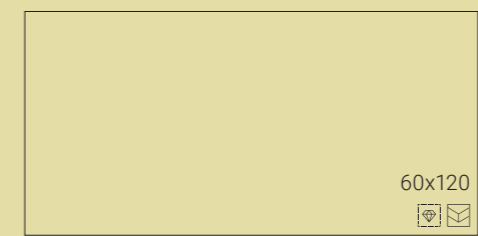

	Formato	Pz/cj	Pz/pl	M ² /cj	M ² /pl	Cj/pl	Kg/cj	Kg/Total
	60x120	2	64	1,44	46,08	32	34,50	1129
	120x120	1	36	1,44	51,84	36	38,40	1422,4
Porcesshine		60x120 / 120x120 23.62"x47.24" / 47.24"x47.24"						



Vanity — Porcesshine



Vanity White 120x120

Vanity



Vanity Black

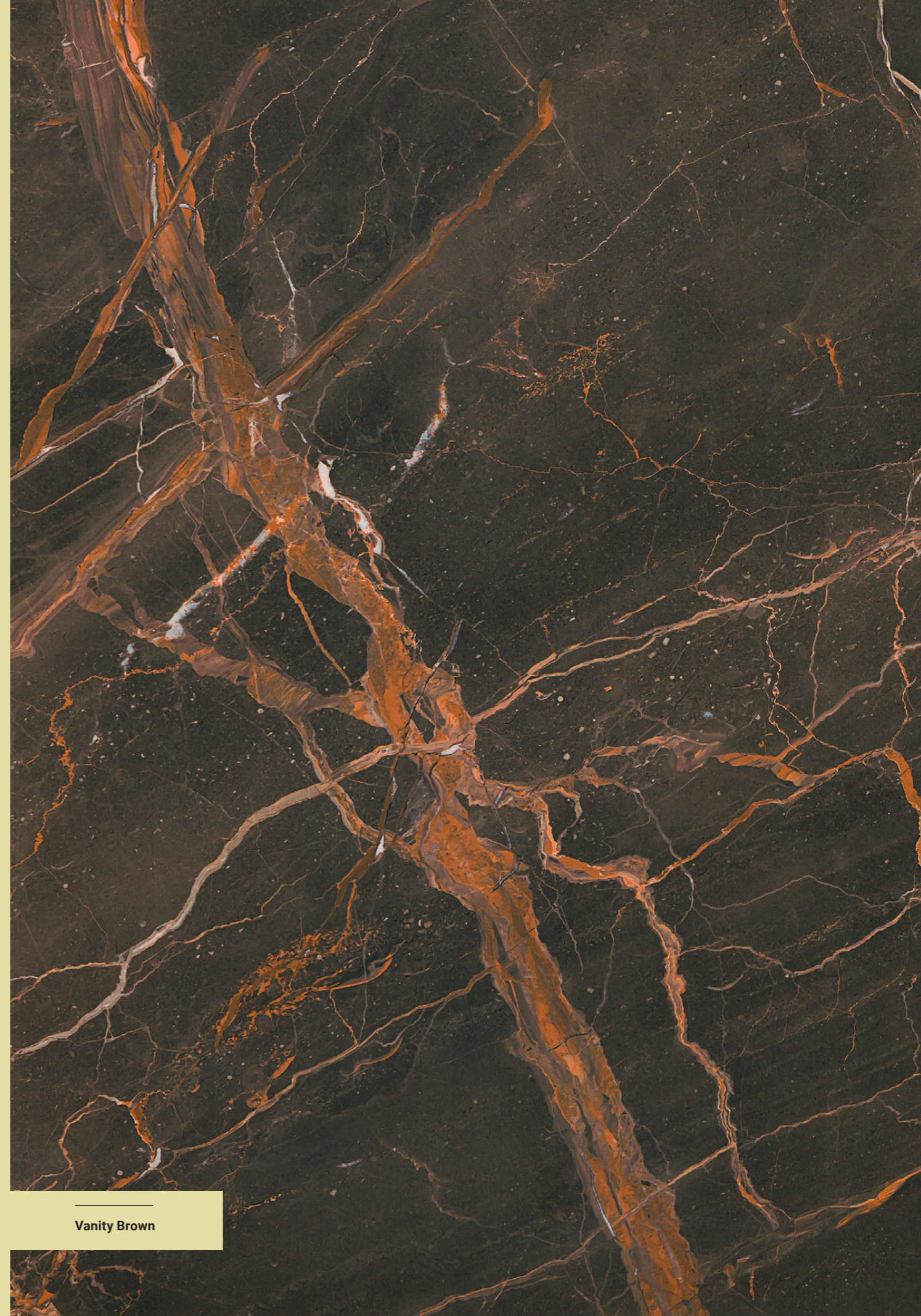

Vanity Brown

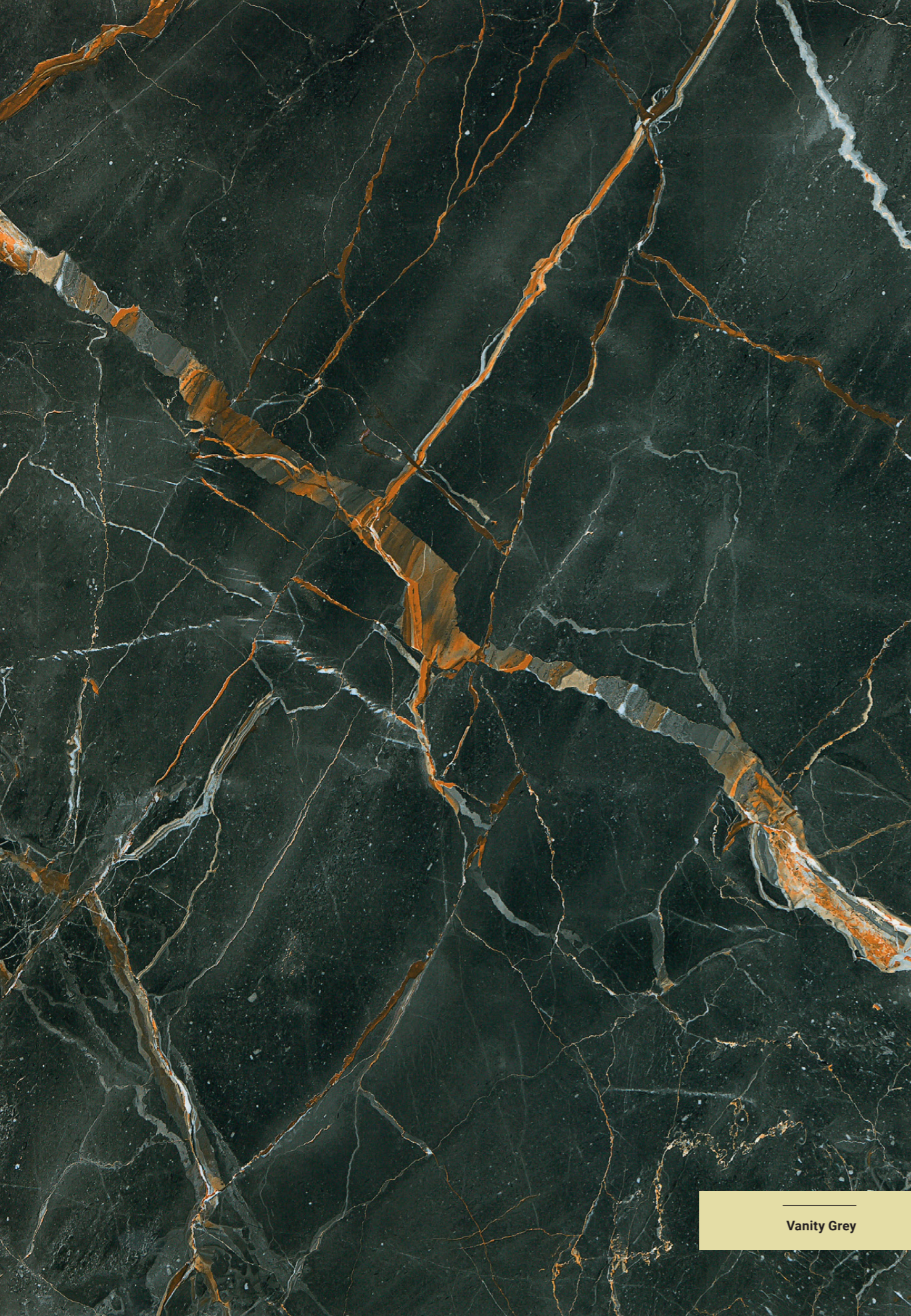

Vanity Grey







Vanity Pearl



Vanity White



Formato	Pz/cj	Pz/pl	M ² /cj	M ² /pl	Cj/pl	Kg/cj	Kg/Total
60x120  	2	64	1,44	46,08	32	34,50	1129
120x120  	1	36	1,44	51,84	36	38,40	1422,4

Porcesshine 60x120 / 120x120
23.62"x47.24" / 47.24"x47.24"

Piezas complementarias
Complementary Tiles / Pièces Complémentaires

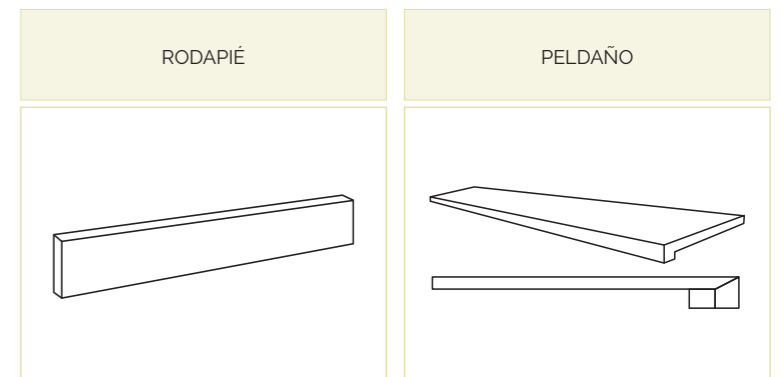

Formatos / Formats

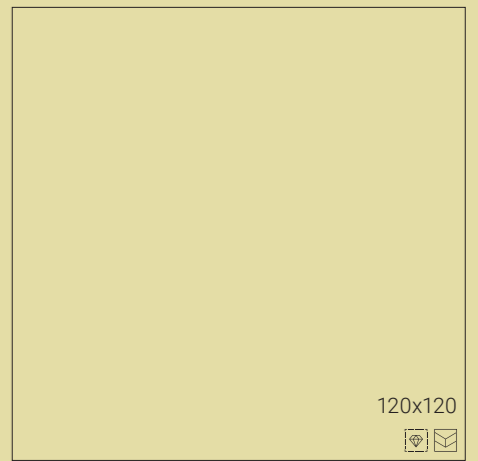

Características técnicas

Technical characteristics
Caractéristiques techniques

Piezas complementarias / Complementary Tiles / Pièces Complémentaires

Disponible peldaños en todos los formatos y acabados. Consultar.

Available steps in all formats and finishes. Consult.

Marches disponibles dans tous les formats et finitions. Consulter.

Ingalls 8x40 Chevron:

Pieza derecha e izquierda en la misma caja / Right and left piece in the same box /

Pièces gauche et droite dans la même boîte

Stones

GRUPO Bla (GL) Absorción de agua < 0,5% GROUPE Bla (GL) Water absorption < 0,5% GROUPE Bla (GL) Absorption d'eau < 0,5%		NORMAS DE ENSAYO STANDARD / NORMES D'ESSAI	VALORES PRESCRITOS NORMA EN 14411 VALUE REQUIRED BY EN 14411 STANDARD / VALEURS PRESCRITES NORME EN 14411	VALOR MEDIO AVERAGE VALUE / VALEUR MOYENNE
Características dimensionales Dimensional features / Caractéristiques dimensionnelles		ISO 10545-2		Cumple la norma Conforms to standard / Satisfait à la norme
Absorción de agua Water absorption / Absorption d'eau		ISO 10545-3	< 0,5%	0,1%
Resistencia a la flexión Modulus of rupture Résistance à la flexion	Resistencia a la flexión Modulus of rupture Résistance à la flexion Fuerza de rotura Breaking strength / Force de rupture	ISO 10545-4	> 35 N / mm ² > 1300 N	35 - 45 N / mm ² 1800 - 2500 N
Resistencia a la abrasión profunda (mm³) Resistance to deep abrasion (mm ³) / Résistance à l'abrasion profonde (mm ³)		ISO 10545-6	Máx. 175 mm ³	110 - 130 mm ³
Dilatación térmica lineal / Linear thermal expansion / Dilatation thermique linéaire		ISO 10545-8	Método de ensayo disponible Test method available / Méthode d'essai disponible	<7,0 x 10 ⁻⁶ °C ⁻¹
Resistencia al choque térmico Thermal shock resistance / Résistance au choc thermique		ISO 10545-9	Método de ensayo disponible Test method available / Méthode d'essai disponible	Resiste Resists / Résiste
Resistencia a la helada Frost resistance / Résistance au gel		ISO 10545-12	Método de ensayo disponible Test method available / Méthode d'essai disponible	Resiste Resists / Résiste
Resistencia química Chemical resistance / Résistance chimique	Ácidos y bases Acids and bases / Acides et bases Productos de limpieza y reactivos de piscinas Cleaning products and pool reactive agents / Produits de nettoyage et réactifs de piscines réactifs de piscines	ISO 10545-13	Método de ensayo disponible Test method available / Test method available Mínimo UB Minimum UB / Minimum UB	Cumple la norma Conforms to standard / Satisfait à la norme Clase UA Class UA / Class UA
Resistencia a las manchas Resistance to stains / Résistance aux taches		ISO 10545-14	Mínimo clase 3 Minimum class 3 / Minimum classe 3	Cumple la norma Conforms to standard / Satisfait à la norme
Resistencia al deslizamiento Slip Resistance / Résistance au glissement		DIN 51130 DIN 51097 UNE-ENV 12633 ASTM C 1028		Según Modelos According to models / Selon modèles

Porceglass

GRUPO Bib (GL) Absorción de agua 0,5% < E< 3% GROUPE Bib (GL) Water absorption 0,5% < E< 3% GROUPE Bib (GL) Absorption d'eau 0,5% < E< 3%		NORMAS DE ENSAYO STANDARD / NORMES D'ESSAI	VALORES PRESCRITOS NORMA EN 14411 VALUE REQUIRED BY EN 14411 STANDARD / VALEURS PRESCRITES NORME EN 14411	VALOR MEDIO AVERAGE VALUE / VALEUR MOYENNE
Características dimensionales Dimensional features / Caractéristiques dimensionnelles		ISO 10545-2		Cumple la norma Conforms to standard / Satisfait à la norme
Absorción de agua Water absorption / Absorption d'eau		ISO 10545-3	0,5% < E< 3%	2%
Resistencia a la flexión Modulus of rupture / Résistance à la flexion	Resistencia a la flexión Modulus of rupture / Résistance à la flexion Fuerza de rotura Breaking strength / Force de rupture	ISO 10545-4	> 30 N / mm ² > 1100 N	35 - 45 N / mm ² 1800 - 2500 N
Resistencia a la abrasión superficial Resistance to surface abrasion / Résistance à l'abrasion de surface		ISO 10545-7	Clase indicada por el fabricante Abrasion class indicated by the manufacturer / Classe indiquée par le fabricant	Según Modelos According to models / Selon modèles
Dilatación térmica lineal Linear thermal expansion / Dilatation thermique linéaire		ISO 10545-8	Método de ensayo disponible Test method available / Méthode d'essai disponible	<7,0 x 10 ⁻⁶ °C ⁻¹
Resistencia al choque térmico Thermal shock resistance / Résistance au choc thermique		ISO 10545-9	Método de ensayo disponible Test method available / Méthode d'essai disponible	Resiste Resists / Résiste
Resistencia al cuarteo Crazing resistance / Résistance au tressailage		ISO 10545-11	Exigida Required / Exigée	Resiste Resists / Résiste
Resistencia química Chemical resistance / Résistance chimique	Ácidos y bases Acids and bases / Acides et bases Productos de limpieza y reactivos de piscinas Cleaning products and pool reactive agents / Produits de nettoyage et réactifs de piscines	ISO 10545-13	Método de ensayo disponible Test method available / Méthode d'essai disponible Mínimo GB Minimum GB / Minimum GB	Cumple la norma Conforms to standard / Satisfait à la norme Clase GA Class GA / Classe GA
Resistencia a las manchas Resistance to stains / Résistance aux taches		ISO 10545-14	Mínimo clase 3 Minimum class 3 / Minimum classe 3	Cumple la norma Conforms to standard / Satisfait à la norme

Porcelux

GRUPO Bla (GL) Absorción de agua 0,5% < E< 3% GROUPE Bla (GL) Water absorption 0,5% < E< 3% GROUPE Bla (GL) Absorption d'eau 0,5% < E< 3%		NORMAS DE ENSAYO STANDARD / NORMES D'ESSAI	VALORES PRESCRITOS NORMA EN 14411 VALUE REQUIRED BY EN 14411 STANDARD / VALEURS PRESCRITES NORME EN 14411	VALOR MEDIO AVERAGE VALUE / VALEUR MOYENNE
Características dimensionales Dimensional features / Caractéristiques dimensionnelles		ISO 10545-2		Cumple la norma Conforms to standard / Satisfait à la norme
Absorción de agua Water absorption / Absorption d'eau		ISO 10545-3	Bla < 0,5%	2%
Resistencia a la flexión Modulus of rupture / Résistance à la flexion	Resistencia a la flexión Modulus of rupture / Résistance à la flexion Fuerza de rotura Breaking strength / Force de rupture	ISO 10545-4	> 30 N / mm ² > 1100 N	35 - 45 N / mm ² 1800 - 2500 N
Resistencia a la abrasión superficial Resistance to surface abrasion / Résistance à l'abrasion de surface		ISO 10545-7	Clase indicada por el fabricante Abrasion class indicated by the manufacturer / Classe indiquée par le fabricant	Según Modelos According to models / Selon modèles
Dilatación térmica lineal Linear thermal expansion / Dilatation thermique linéaire		ISO 10545-8	Método de ensayo disponible Test method available / Méthode d'essai disponible	<7,0 x 10 ⁻⁶ °C ⁻¹
Resistencia al choque térmico Thermal shock resistance / Résistance au choc thermique		ISO 10545-9	Método de ensayo disponible Test method available / Méthode d'essai disponible	Resiste Resists / Résiste
Resistencia al cuarteo Crazing resistance / Résistance au tressailage		ISO 10545-11	Exigida Required / Exigée	Resiste Resists / Résiste
Resistencia química Chemical resistance / Résistance chimique	Ácidos y bases Acids and bases / Acides et bases Productos de limpieza y reactivos de piscinas Cleaning products and pool reactive agents / Produits de nettoyage et réactifs de piscines	ISO 10545-13	Método de ensayo disponible Test method available / Méthode d'essai disponible Mínimo GB Minimum GB / Minimum GB	Cumple la norma Conforms to standard / Satisfait à la norme Clase GA Class GA / Classe GA
Resistencia a las manchas Resistance to stains / Résistance aux taches		ISO 10545-14	Mínimo clase 3 Minimum class 3 / Minimum classe 3	Cumple la norma Conforms to standard / Satisfait à la norme

Porcesshine

GRUPO Bla (GL) Absorción de agua 0,5% < E< 3% GROUPE Bla (GL) Water absorption 0,5% < E< 3% GROUPE Bla (GL) Absorption d'eau 0,5% < E< 3%		NORMAS DE ENSAYO STANDARD / NORMES D'ESSAI	VALORES PRESCRITOS NORMA EN 14411 VALUE REQUIRED BY EN 14411 STANDARD / VALEURS PRESCRITES NORME EN 14411	VALOR MEDIO AVERAGE VALUE / VALEUR MOYENNE
Características dimensionales Dimensional features / Caractéristiques dimensionnelles		ISO 10545-2		Cumple la norma Conforms to standard / Satisfait à la norme
Absorción de agua Water absorption / Absorption d'eau		ISO 10545-3	Bla < 0,5%	2%
Resistencia a la flexión Modulus of rupture / Résistance à la flexion	Resistencia a la flexión Modulus of rupture / Résistance à la flexion Fuerza de rotura Breaking strength / Force de rupture	ISO 10545-4	> 30 N / mm ² > 1100 N	35 - 45 N / mm ² 1800 - 2500 N
Resistencia a la abrasión superficial Resistance to surface abrasion / Résistance à l'abrasion de surface		ISO 10545-7	Clase indicada por el fabricante Abrasion class indicated by the manufacturer / Classe indiquée par le fabricant	Según Modelos According to models / Selon modèles
Dilatación térmica lineal Linear thermal expansion / Dilatation thermique linéaire		ISO 10545-8	Método de ensayo disponible Test method available / Méthode d'essai disponible	<7,0 x 10 ⁻⁶ °C ⁻¹
Resistencia al choque térmico Thermal shock resistance / Résistance au choc thermique		ISO 10545-9	Método de ensayo disponible Test method available / Méthode d'essai disponible	Resiste Resists / Résiste
Resistencia al cuarteo Crazing resistance / Résistance au tressailage		ISO 10545-11	Exigida Required / Exigée	Resiste Resists / Résiste
Resistencia química Chemical resistance / Résistance chimique	Ácidos y bases Acids and bases / Acides et bases Productos de limpieza y reactivos de piscinas Cleaning products and pool reactive agents / Produits de nettoyage et réactifs de piscines	ISO 10545-13	Método de ensayo disponible Test method available / Méthode d'essai disponible Mínimo GB Minimum GB / Minimum GB	Cumple la norma Conforms to standard / Satisfait à la norme Clase GA Class GA / Classe GA
Resistencia a las manchas Resistance to stains / Résistance aux taches		ISO 10545-14	Mínimo clase 3 Minimum class 3 / Minimum classe 3	Cumple la norma Conforms to standard / Satisfait à la norme

prismacer
cerámica

RECOMENDACIONES PARA LA LIMPIEZA DE DECORADOS Y PIEZAS ESPECIALES

Debido a las características de los metales utilizados en la confección de estos productos. Es suficiente utilizar una bayeta húmeda y jabón líquido neutro. Si la pieza llevara protección no quitarla hasta que el producto esté colocado y limpio. No se atenderán reclamaciones una vez colocado el producto.

RECOMMENDATIONS FOR THE CLEANING OF DECORATIVE AND SPECIAL PIECES

Due to the characteristics of the metals used in the production of these pieces, only a damp cloth and neutral liquid soap are required to clean them. Any protective material should be left on the piece until it is fitted and clean. Complaints will not be considered once the product has been fitted.

RECOMMANDATIONS CONCERNANT LE NETTOYAGE DES DECORS ET PIECES SPECIALES

Dues aux caractéristiques des métaux utilisés lors de la confection de ses produits, il est suffisant d'utiliser une éponge humide et du savon neutre. Dans le cas où la pièce porterait une protection, ne pas l'enlever jusqu'à ce que le produit soit posé et nettoyé. Aucune réclamation ne sera acceptée une fois le produit Pamesa posé.

PRISSMACER CERÁMICA S.L.U. aplica una política de continuo desarrollo de sus productos y se reserva el derecho a realizar cambios en los productos, colores, especificaciones técnicas, packings y códigos sin previo aviso. PRISSMACER CERÁMICA S.L.U. ha realizado un esfuerzo considerable para que toda la información sea adecuada en el momento de la publicación del catálogo. A causa de las limitaciones del proceso de impresión los colores reproducidos pueden sufrir ligeras variaciones con respecto al producto original. PRISSMACER CERÁMICA S.L.U. informa que este catálogo tiene validez a nivel informativo y por tanto no se hace responsable de los posibles errores de impresión; reservándose el derecho de realizar modificaciones sin necesidad de preaviso.

PRISSMACER CERÁMICA S.L.U. operates a policy of continuous development and reserves the right to make changes to its products, colours, engineering specifications, packaging and codes without prior notice. PRISSMACER CERÁMICA S.L.U. has taken every effort to ensure that the information contained in the catalogue is correct at the time of publication. Due to the limitations of the printing process, the colours reproduced may vary slightly from the original product. PRISSMACER CERÁMICA S.L.U. advises that this catalogue is only valid for information purposes and therefore does not accept responsibility for any possible printing errors.

PRISSMACERCERÁMICAS.L.U.applique une politique de développement continu de ses produits et se réserve le droit de réaliser des changements, que ce soit de produits, couleurs, spécifications techniques, paquetages et codifications et cela sans en aviser préalablement l'acheteur. PRISSMACER CERÁMICAS.L.U. a réalisé un effort considérable pour que toute l'information donnée soit adéquate au moment de la publication du catalogue. Dues aux limitations du processus d'impression, les couleurs reproduites peuvent souffrir de légères variations avec le produit original. PRISSMACER CERÁMICA S.L.U. vous informe que les informations de ce catalogue sont données à titre informatif et qu'elle n'est pas responsable des possibles erreurs d'impression. De plus, elle se réserve le droit de modifier les informations sans préavis.

PRISSMACER CERÁMICA S.L.U.
Camino Ratils, 23
Polígono Industrial Colomer
12200 Onda, Castellón (España)
Tel: (+34) 964 500 226
info@prissmacer.es
@prissmacer_tiles

www.prissmacer.es